

BR
EE
EE
S
H
H

GEO THERMAL HEAT PUMP TECHNOLOGY MANUAL



HISEER

What is geothermal heat pump?

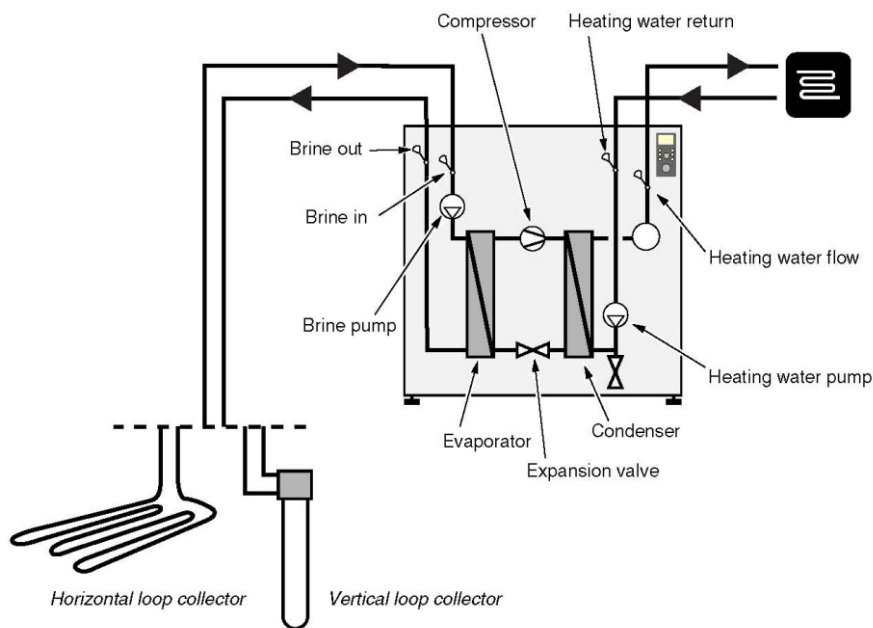

Geothermal heat pumps (GHP) are a relatively new technology that can save homeowners money. These ground-source heat pumps use the natural heat storage capacity of the earth or ground water to provide energy efficient heating, hot water. Geothermal heating can be more efficient than electric resistance heating. These systems are also typically more efficient than gas or oil-fired heating systems. They are more energy efficient than air-source heat pumps because they draw heat from, or release heat to, the earth, which has moderate temperatures year round, rather than to the air (which is

generally colder in winter and warmer in summer than the earth, resulting in less effective heat transfer). Geothermal heat pumps have demonstrated energy savings over air heat pumps because they extract energy from the constant temperature of the earth (via a water pipe buried in the earth) to condition the air in a home. In a sense, geothermal is a partially-renewable form of energy.

The heating medium is pumped up from the borehole in tubing and passed to evaporator of heat pump and its energy is absorbed by refrigerant circulated in another closed circuit. The evaporated refrigerant is fed to a compressor where it is compressed and result in a high increase in temperature. The warm refrigerant is fed to the condenser, which is positioned in the boiler water. Here the refrigerant gives off its energy to the boiler water, so that its temperature drops and the refrigerant changes state from gas to liquid.

The refrigerant then goes via filters to an expansion valve, where the pressure and temperature are further reduced. The refrigerant has now completed its circuit and is once more fed into the evaporator where it is evaporated yet again due to the effect of the energy that the collector has carried from the energy source.

Characteristic:

01. Heating cost taper off at an increasing rate in the future.
02. Heating is maintenance-free.
03. Your house is emissions-free-good for your personal environment.
04. You never have to worry about your energy supply disappearing.
05. No extra boiler room is necessary.
06. You don't need a chimney or extra tank room.
07. No danger from fuels for you and your loved ones.
08. No gas connection.
09. You help save important resources.

A GHP system consists of indoor heat pump equipment, a ground loop, and a flow center to connect the indoor and outdoor equipment. The heat pump equipment works like a reversible refrigerator by removing heat from one location and depositing it in another location. The ground loop, which is invisible after installation, allows the exchange of heat between the earth and the heat pump. Desuperheaters can be added to supplement the production of domestic hot water when there is a demand for space heating or cooling. These devices make use of excess heat during the cooling cycle and use some of the heat during the heating cycle to supplement hot water production. Dedicated water heaters can be added which operate whenever there is a demand for hot water.

HISEER

Typical application

Ground source heat pumps can be categorized as having closed or open loops, and those loops can be installed in three ways: horizontally, vertically, or in a pond/lake. Closed-loop systems use a water and antifreeze solution, circulated in a ground loop of pipe to extract heat from the earth.

1. Vertical loop system

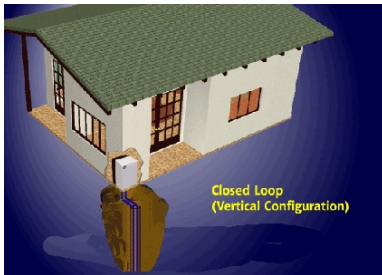

A vertical ground loop system may be installed in vertical bore holes 150 to 500 feet deep (46 to 152m). Each hole contains a single loop of pipe. After the pipe is inserted, the hole is backfilled and grouted. The number of loops required depends on ground conditions, air conditioning and heating load and the depth of each hole. This design is well suited for retrofit applications where landscaping is already complete.

2. Horizontal loop system

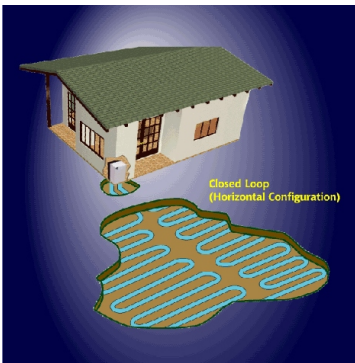

A horizontal ground loop system is usually selected when adequate space is available and trenching can be easily accomplished. A series of parallel pipes are laid out in trenches 3 to 6 (9 to 1.8 m) feet below the ground surface. Then backfilled. Often multiple pipes are used to maximize the heat transfer capability of each trench. The amount of pipe and the size of the ground loop field is based on ground conditions, heating and cooling requirement.

3. Surface water system

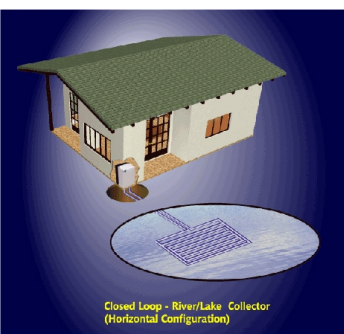

An application located near a lake or pond can benefit from a surface water system. Many local building codes require a retention pond to contain rain run off from large roof and parking area of new buildings. These retention ponds can become low cost and efficient energy sources. Because of the excellent thermal property of water, a loop may be submerged in a series of coils beneath the water surface when an application is located near a lake or pond.

HISEER

Performance Data

Heat pump	Type	GSWW8	GSWW10	GSWW13	GSWW15	
Dimensions, weights, connection dimensions						
Dimensions	HxWxD	1000x600X600				
Weight	kg	105	110	120	130	
Refrigerant	Type	R407C				
Filling weight	kg	2	2.3	2.5	2.8	
Permissible operating pressure	Mpa	3	3	3	3	
Pipe connector-hot side	Inch	G1"	G1"	G1"	G1"	
Pipe connector-cold side	Inch	G1"	G1"	G1"	G1"	
Evaporator	Type	Braze plate heat exchanger				
Condenser	Type	Braze plate heat exchanger				
Compressor		1xScroll	1xScroll	1xScroll	1xScroll	
Performance Heat pump						
Heat output	at B0/W35 ⁽¹⁾	kW	8	10.2	13.1	15.5
Power consumption		kW	1.9	2.36	2.95	3.53
Performance factor			4.21	4.32	4.44	4.39
Heat output	at W10/W35 ⁽²⁾	kW	10.1	12.9	16.7	19.6
Power consumption		kW	1.89	2.39	3.01	3.57
Performance factor			5.34	5.4	5.55	5.49
Process medium			Brine/water values in []			
Process medium			Brine made from water with 33Vol.% ethylene glycol			
Volume flow	hot side	m ³ /h	0.88[0.72]	1.1[0.9]	1.4[1.2]	1.7[1.4]
	cold side	m ³ /h	2.1[1.8]	2.6[2.2]	3.4[3.1]	4.1[3.7]
Power	Type	Single phase	Single phase	Triple phase	Triple phase	
Sound power level	dB(A)	46	47	48	48	

(1)B0/W35 = Brine water inlet temperature 0°C, heating flow 35°C

(2)W10/W35 = Well water inlet temperature 10°C, heating flow 35°C

HISEER

Performance Data

Heat pump		Type	GSWW20	GSWW26	GSWW30
Dimensions, weights, connection dimensions					
Dimensions	HxWxD	1000x800X600			
Weight	kg	180	195	210	
Refrigerant	Type	R407C			
Filling weight	kg	4	4.5	5	
Permissible operating pressure	Mpa	3	3	3	
Pipe connector-hot side	Inch	G1 ¹ / ₄ "	G1 ¹ / ₄ "	G1 ¹ / ₄ "	
Pipe connector-cold side	Inch	G1 ¹ / ₄ "	G1 ¹ / ₄ "	G1 ¹ / ₄ "	
Evaporator	Type	Braze plate heat exchanger			
Condenser	Type	Braze plate heat exchanger			
Compressor		2xScroll	2xScroll	2xScroll	
Performance Heat pump					
Heat output	at B0/W35 ⁽¹⁾	kW	20	26	30.5
Power consumption		kW	4.45	5.8	6.85
Performance factor			4.49	4.48	4.45
Heat output	at W10/W35 ⁽²⁾	kW	25.8	33.3	39
Power consumption		kW	4.7	6.1	7.1
Performance factor			5.49	5.46	5.49
Process medium			Brine/water values in []		
Process medium			Brine made from water with 33Vol.% ethylene glycol		
Volume flow	hot side	m ³ /h	2.2[1.8]	2.8[2.4]	3.4[2.8]
	cold side	m ³ /h	5.2[4.4]	6.8[6.2]	8.2[7.4]
Power	Type	Triple phase			
Sound power level	dB(A)	49	49	49	

(1) B0/W35 = Brine water inlet temperature 0°C, heating flow 35°C

(2) W10/W35 = Well water inlet temperature 10°C, heating flow 35°C

HISEER

Performance Data

Heat pump with cooling	Type	GSWW8/C	GSWW10/C	GSWW13/C	GSWW15/C	
Dimensions, weights, connection dimensions						
Dimensions	HxWxD	1000x600X600 mm				
Weight	kg	105	110	120	130	
Refrigerant	Type	R407C				
Filling weight	kg	2	2.3	2.5	2.8	
Permissible operating pressure	Mpa	3	3	3	3	
Pipe connector-hot side	Inch	G1"	G1"	G1"	G1"	
Pipe connector-cold side	Inch	G1"	G1"	G1"	G1"	
Evaporator	Type	Brazen plate heat exchanger				
Condenser	Type	Brazen plate heat exchanger				
Compressor		1xScroll	1xScroll	1xScroll	1xScroll	
Performance Heating						
Heat output	at B0/W35 ⁽¹⁾	kW	8	10.2	13.1	15.5
Power consumption		kW	1.9	2.36	2.95	3.53
Performance factor			4.21	4.32	4.44	4.39
Heat output	at W10/W35 ⁽²⁾	kW	10.1	12.9	16.7	19.6
Power consumption		kW	1.89	2.39	3.01	3.57
Performance factor			5.34	5.4	5.55	5.49
Process medium			Brine/water values in []			
Process medium			Brine made from water with 33Vol.% ethylene glycol			
Volume flow	inside	m3/h	0.88[0.72]	1.1[0.9]	1.4[1.2]	1.7[1.4]
	outside	m3/h	2.1[1.8]	2.6[2.2]	3.4[3.1]	4.1[3.7]
Performance Cooling						
Cooling output	at W20/W7 ⁽³⁾	kW	9.2	12	15	18
Power consumption		kW	1.65	2.1	2.6	3.2
Performance factor			5.58	5.71	5.77	5.63
Volume flow	inside	m3/h	1.58	2.1	2.58	3.1
	outside	m3/h	2.1	2.6	3.4	4.1
Power	Type	Single phase	Single phase	Triple phase	Triple phase	
Sound power level	dB(A)	46	47	48	48	

(1)B0/W35=Brine water inlet temperature 0°C,heating flow 35°C

(2)W10/W35=Well water inlet temperature 10°C,heating flow 35°C

(3)W20/W7=Outside water inlet temperature 20°C,cooling flow 7°C

HISEER

Performance Data

Heat pump with cooling		Type	GSWW20/C	GSWW26/C	GSWW30/C
Dimensions, weights, connection dimensions					
Dimensions		HxWxD	1000x800X600 mm		
Weight		kg	180	195	210
Refrigerant		Type	R407C		
Filling weight		kg	4	4.5	5
Permissible operating pressure		Mpa	3	3	3
Pipe connector-hot side		Inch	G1 ¹ / ₄ "	G1 ¹ / ₄ "	G1 ¹ / ₄ "
Pipe connector-cold side		Inch	G1 ¹ / ₄ "	G1 ¹ / ₄ "	G1 ¹ / ₄ "
Evaporator		Type	Braze plate heat exchanger		
Condenser		Type	Braze plate heat exchanger		
Compressor			2xScroll	2xScroll	2xScroll
Performance Heat pump					
Heat output	at B0/W35 ⁽¹⁾	kW	20	26	30.5
Power consumption		kW	4.45	5.8	6.85
Performance factor			4.49	4.48	4.45
Heat output	at W10/W35 ⁽²⁾	kW	25.8	33.3	39
Power consumption		kW	4.7	6.1	7.1
Performance factor			5.49	5.46	5.49
Process medium			Brine/water values in []		
Process medium			Brine made from water with 33Vol.% ethylene glycol		
Volume flow	inside	m ³ /h	2.2[1.8]	2.8[2.4]	3.4[2.8]
	outside	m ³ /h	5.2[4.4]	6.8[6.2]	8.2[7.4]
Performance Cooling					
Cooling output	at W20/W7 ⁽³⁾	kW	24	30	36
Power consumption		kW	4.1	5.2	6.4
Performance factor			5.85	5.77	5.63
Volume flow	inside	m ³ /h	4.2	5.2	6.2
	outside	m ³ /h	5.2	6.8	8.2
Power	Type	Triple phase			
Sound power level	dB(A)	49	49	49	

(1)B0/W35=Brine water inlet temperature 0°C,heating flow 35°C

(2)W10/W35=Well water inlet temperature 10°C,heating flow 35°C

(3)W20/W7=Outside water inlet temperature 20°C,cooling flow 7°C

HISEER

Installation

1. Outboard 3 way valve and water pump

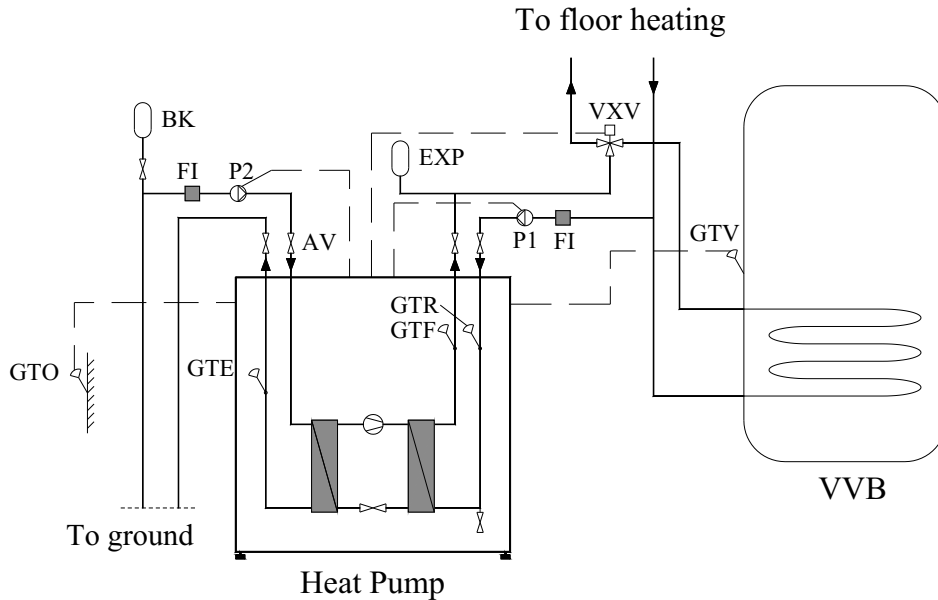

2. Built-in 3 way valve and water pump

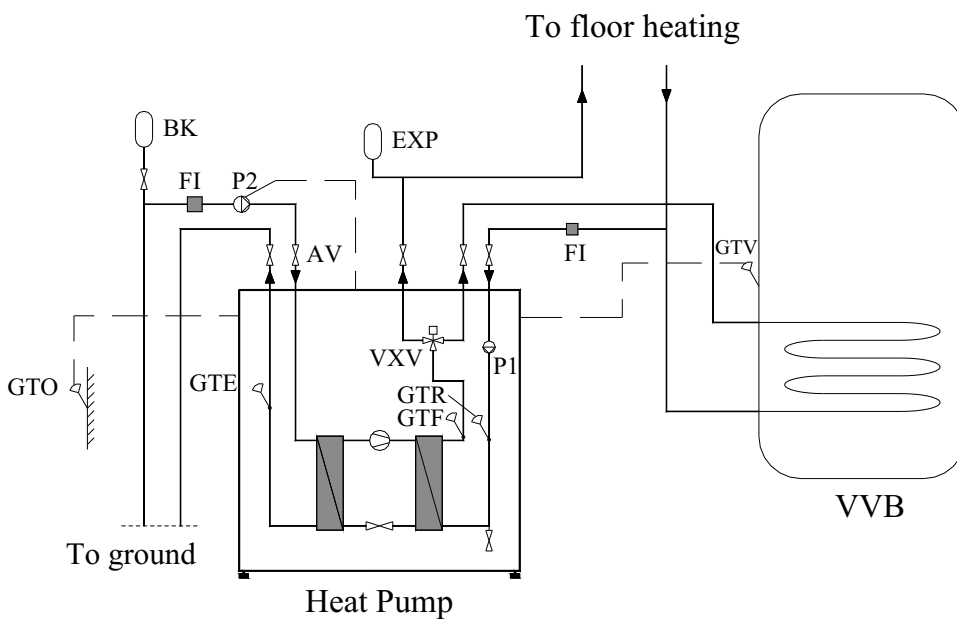

Name	Description	Included?	Name	Description	Included?
BK	Brine tank/expansion tank	Extra	FI	Filter	Extra
EXP	Expansion tank	Extra-	GTR	Return temp. sensor	Standard
P1	Circulation pump for heat pump	Option	GTV	D.h.w sensor	Standard
P2	Brine pump	Option	GTO	Outdoor temp. sensor	Standard
VXV	Change over valve	Option	GTE	Brine water flow sensor	Standard
VVB	Hot water tank	Option	GTF	Flow temp. sensor	Standard
AV	shut-off valve	Extra			

HISEER

Dimension

GSWW10 GSWW13 GSWW15

Unit:mm

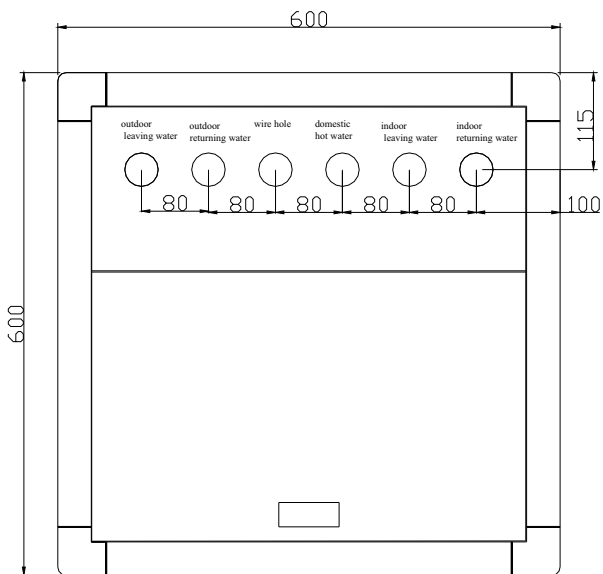
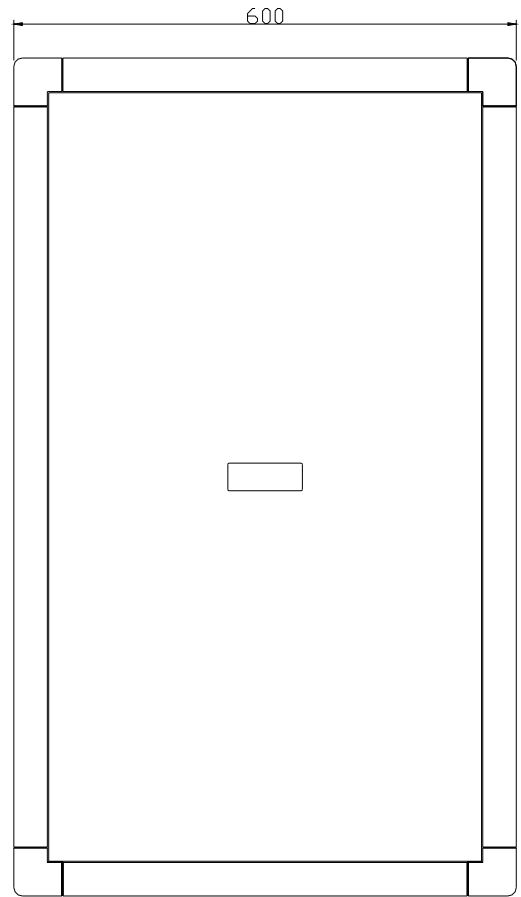
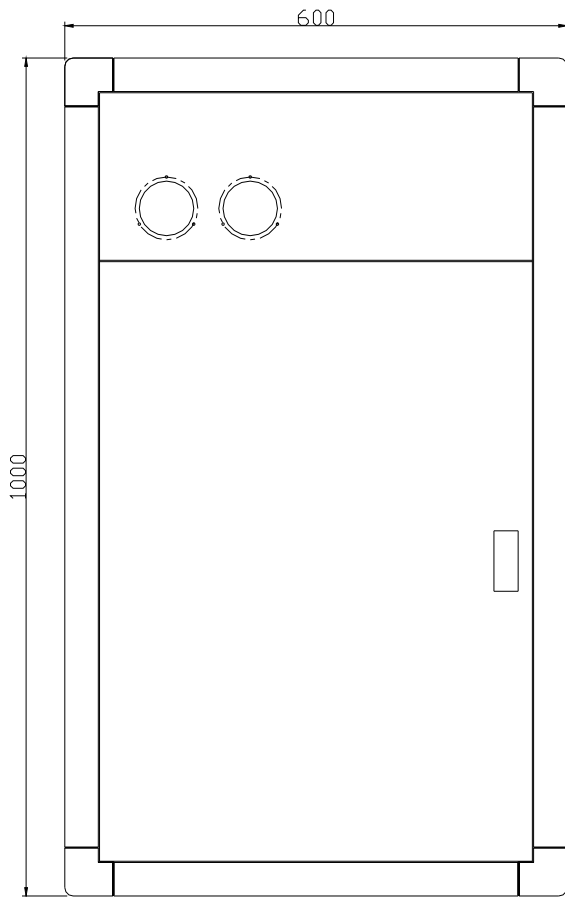

HISEER

Dimension

GSWW20 GSWW26 GSWW30

Unit:mm

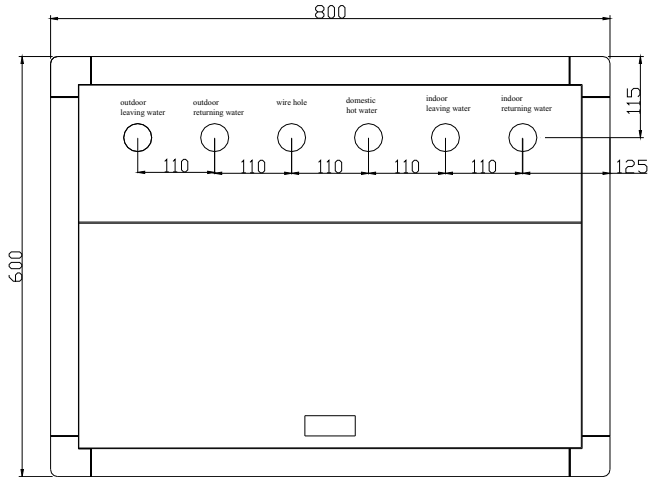
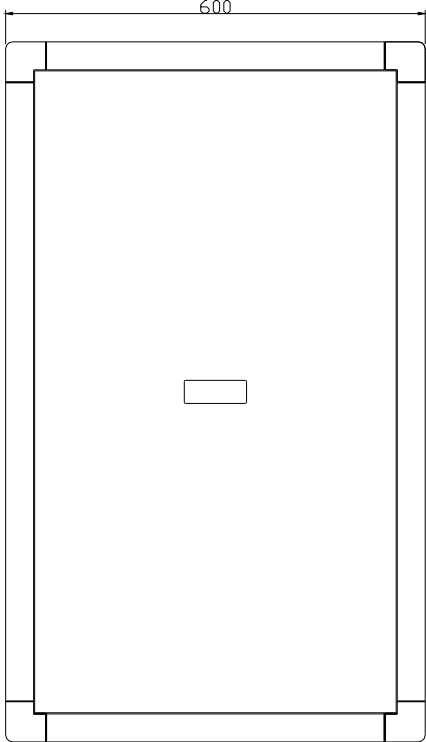
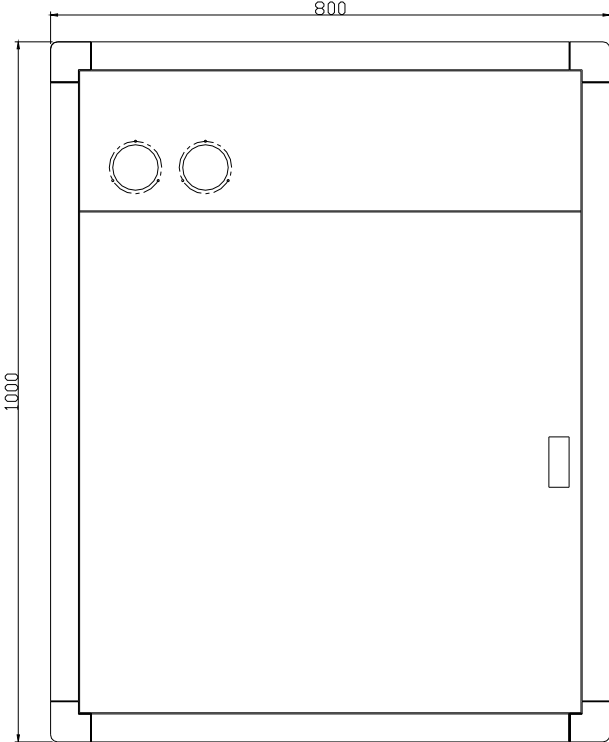

HISEER

Performance Conditions Curve

Model:GSWW8

Water with 33Vol.% ethylene glycol

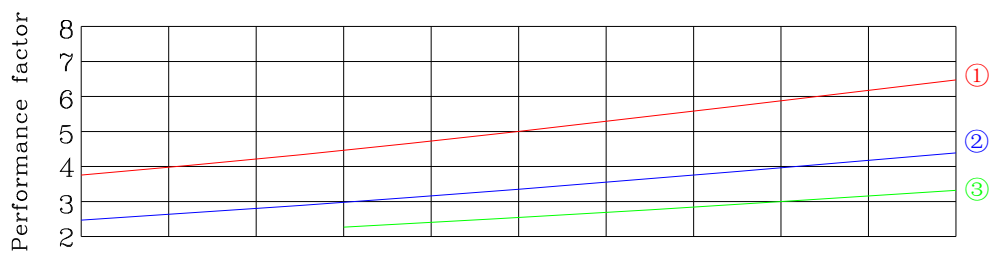
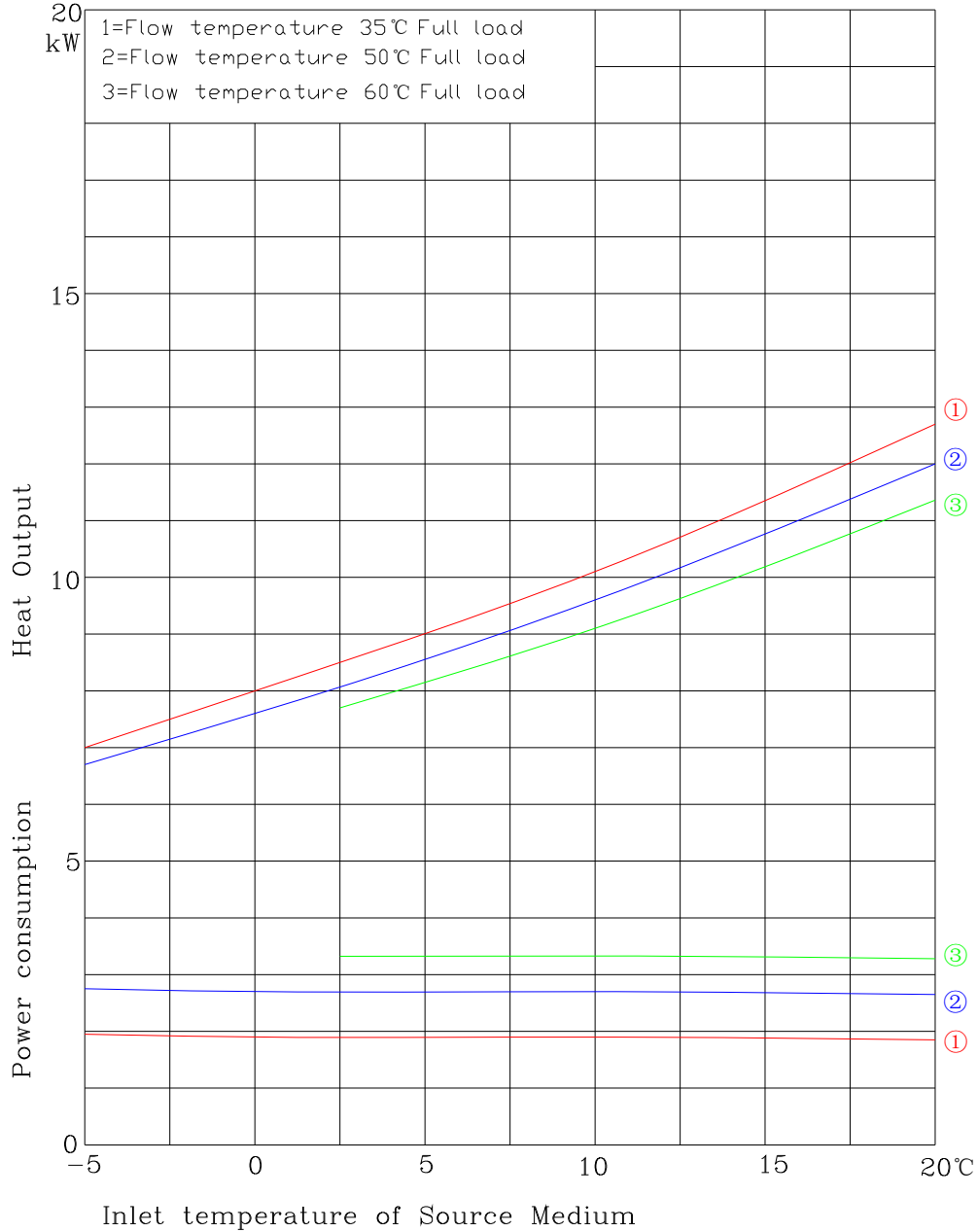

HISEER

Performance Conditions Curve

Model:GSWW8

Water

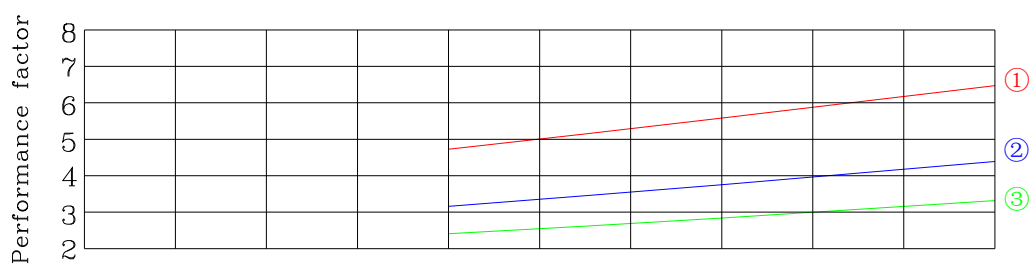
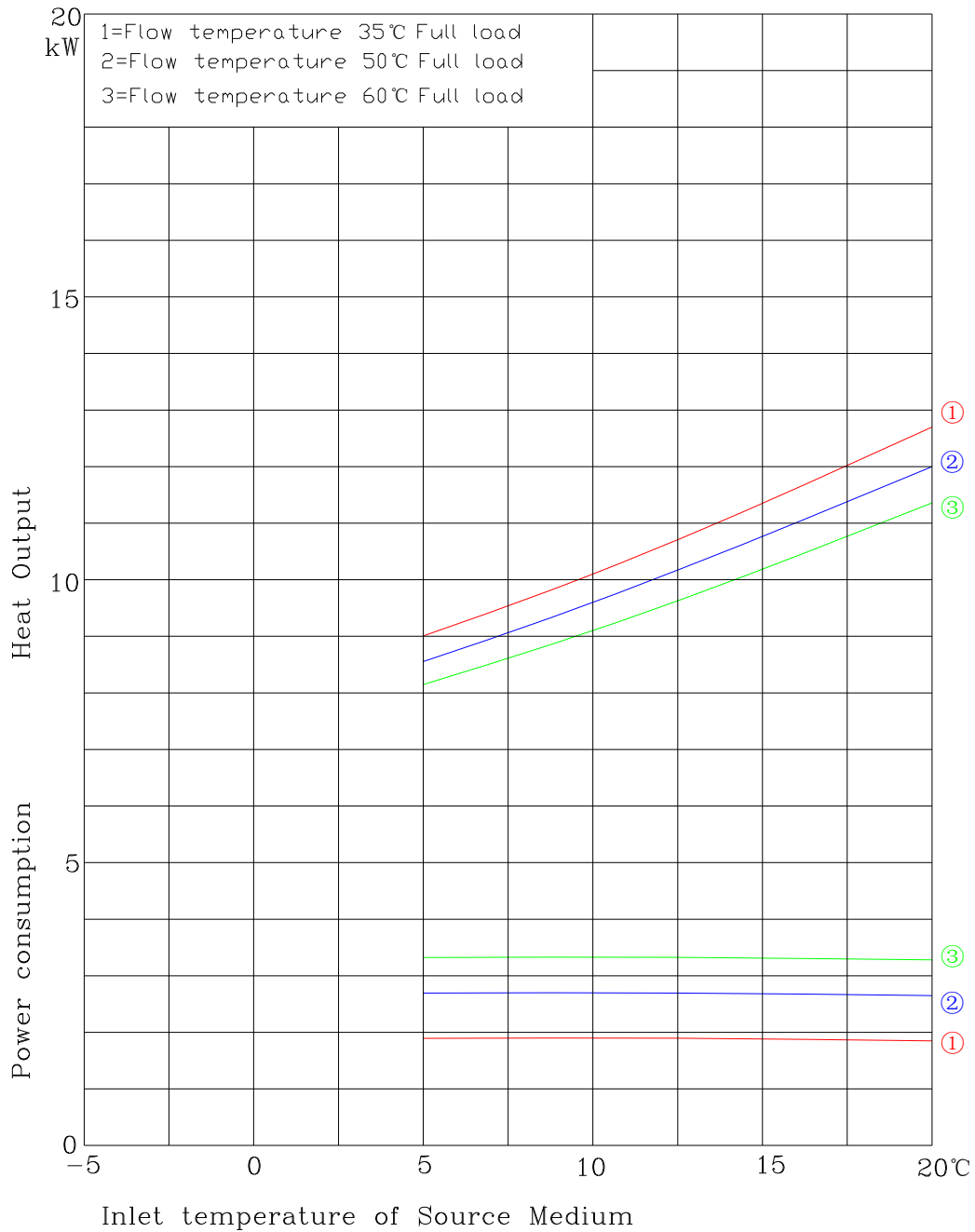

HISEER

Performance Conditions Curve

Model:GSWW10

Water with 33Vol.% ethylene glycol

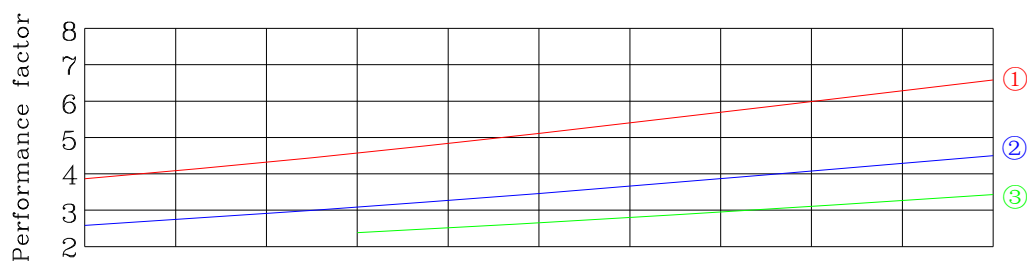
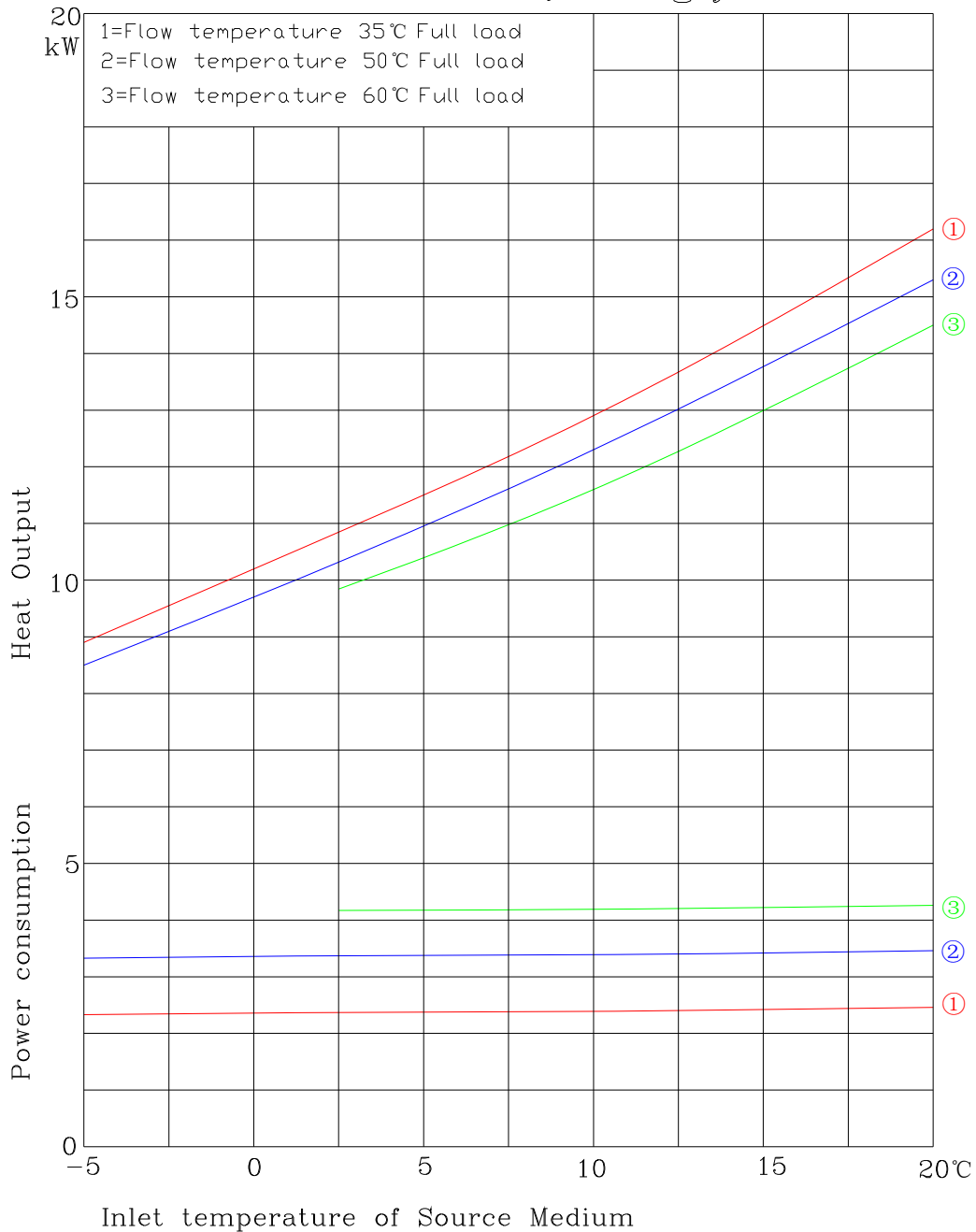

HISEER

Performance Conditions Curve

Model:GSWW10

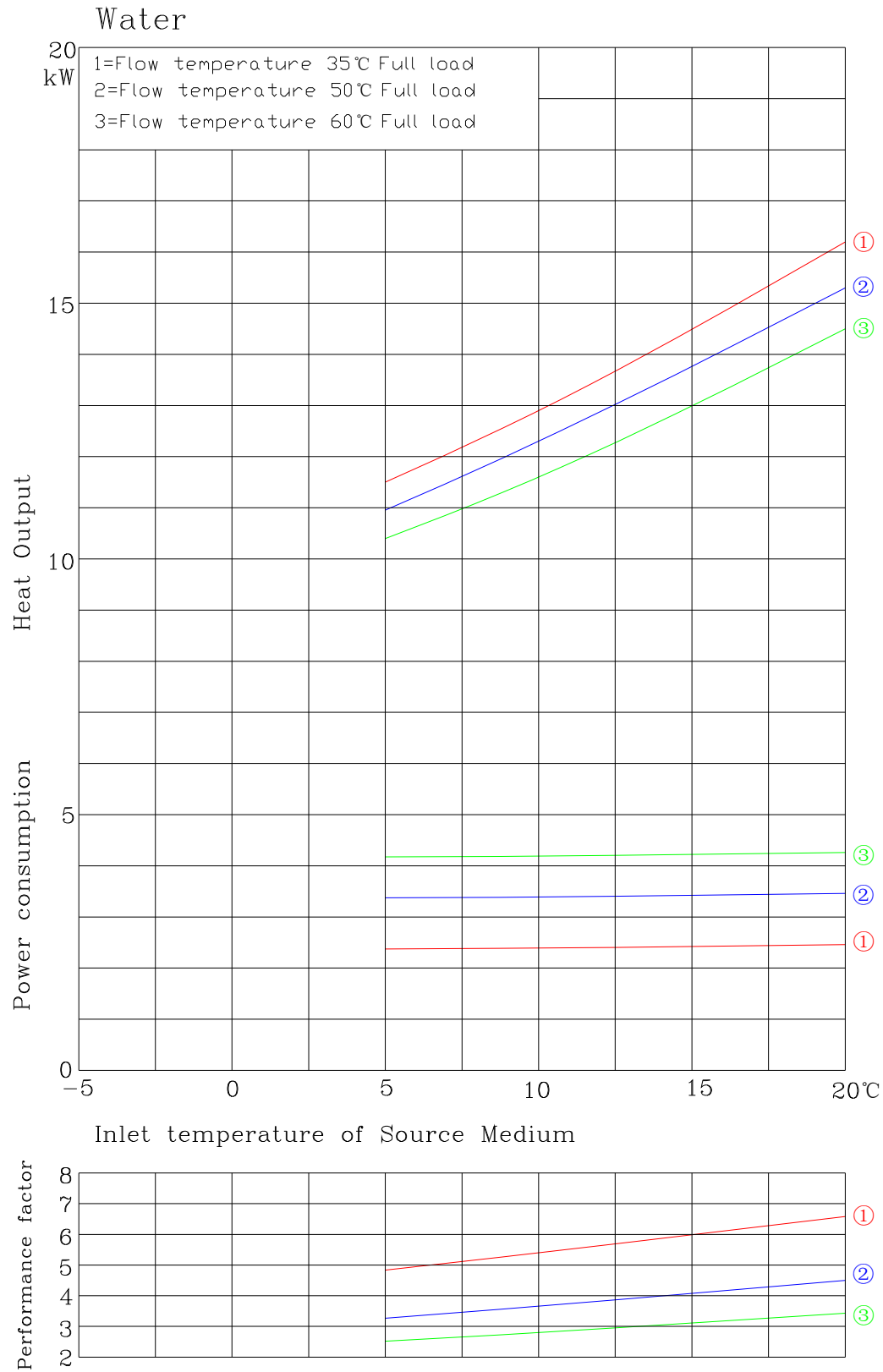

HISEER

Performance Conditions Curve

Model:GSWW13

Water with 33Vol.% ethylene glycol

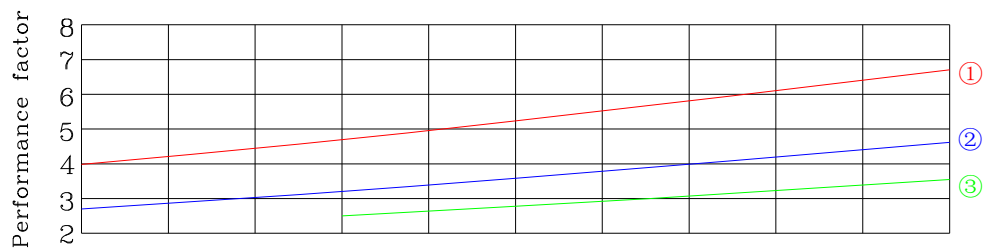
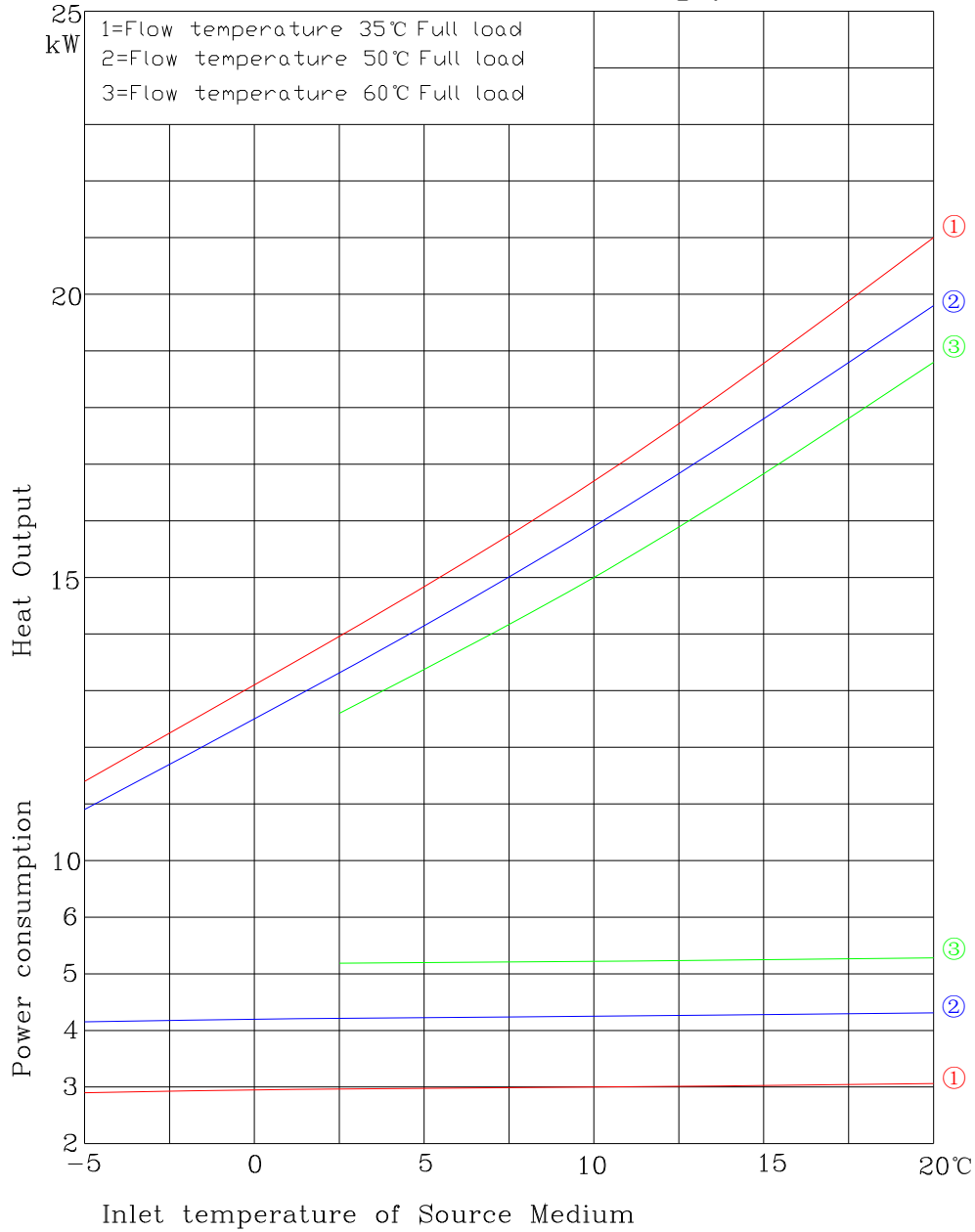

HISEER

Performance Conditions Curve

Model:GSWW13

Water

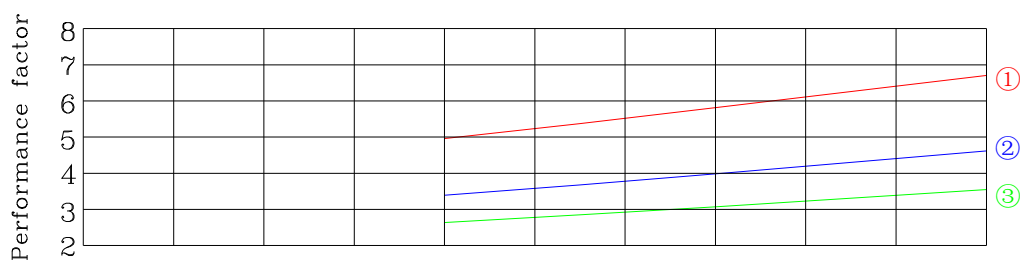
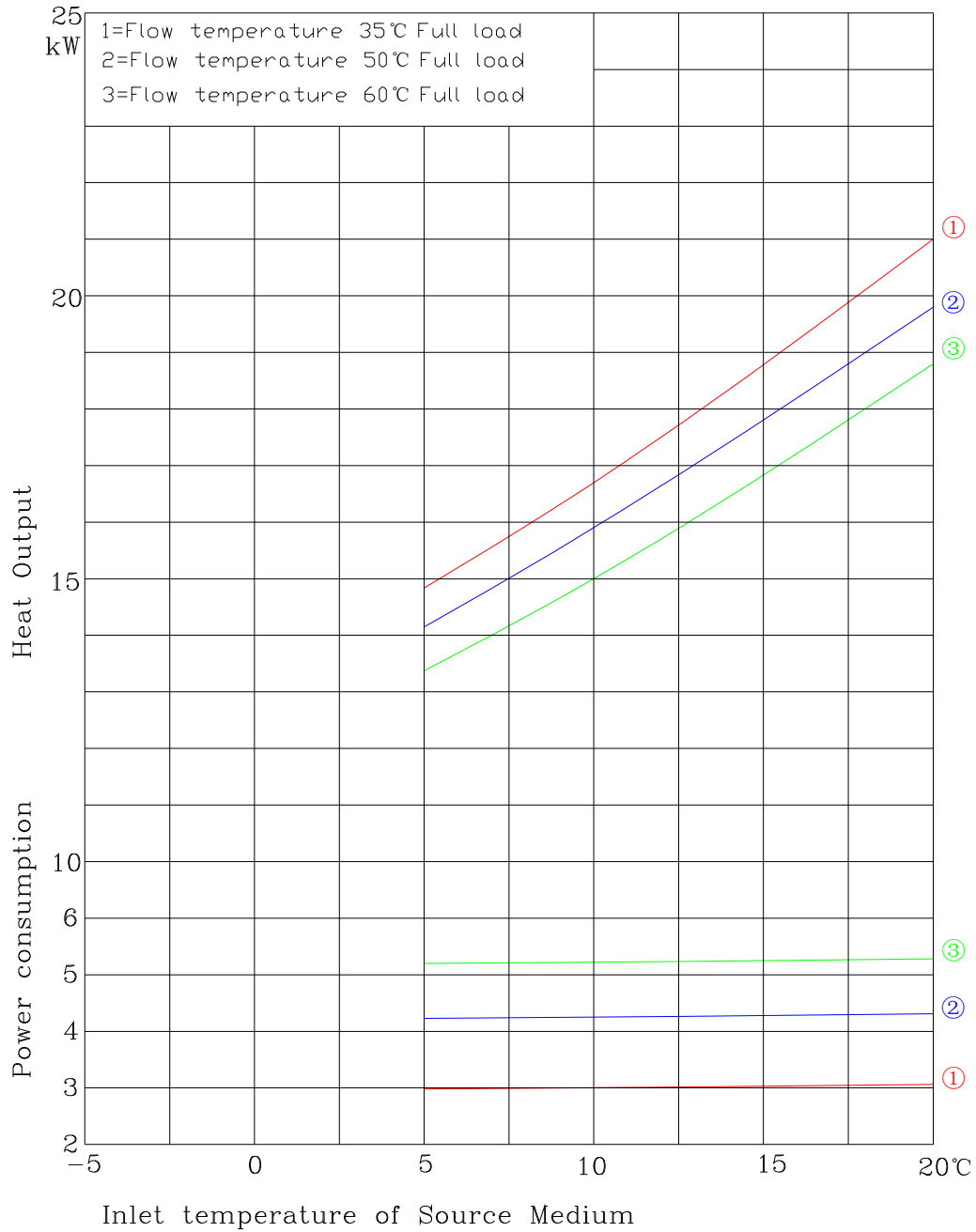

HISEER

Performance Conditions Curve

Model:GSWW15

Water with 33Vol.% ethylene glycol

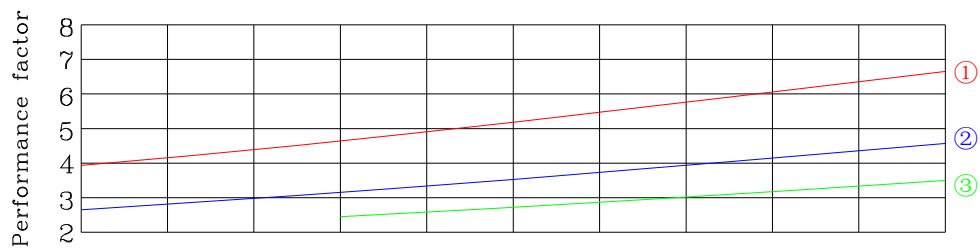
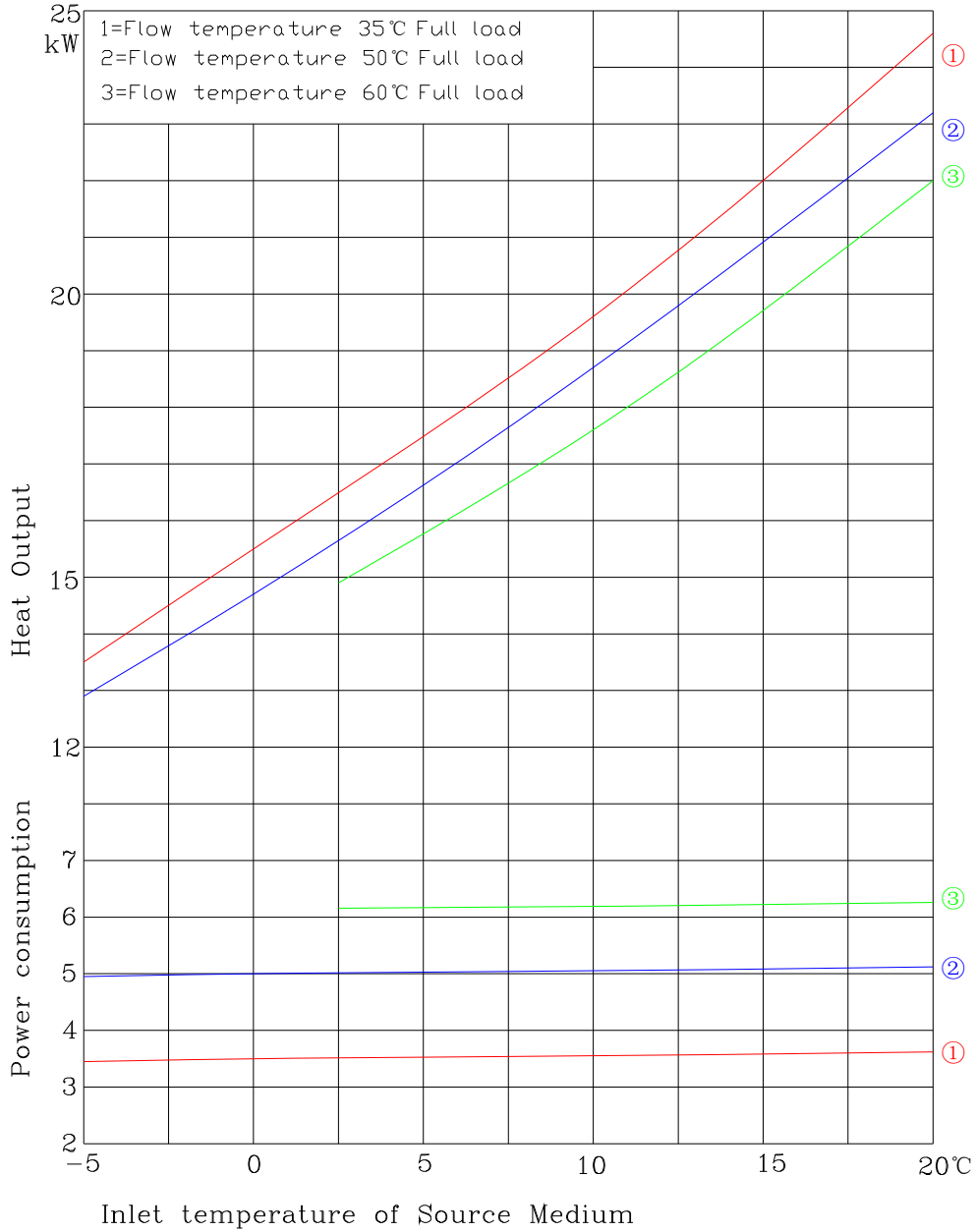

HISEER

Performance Conditions Curve

Model:GSWW15

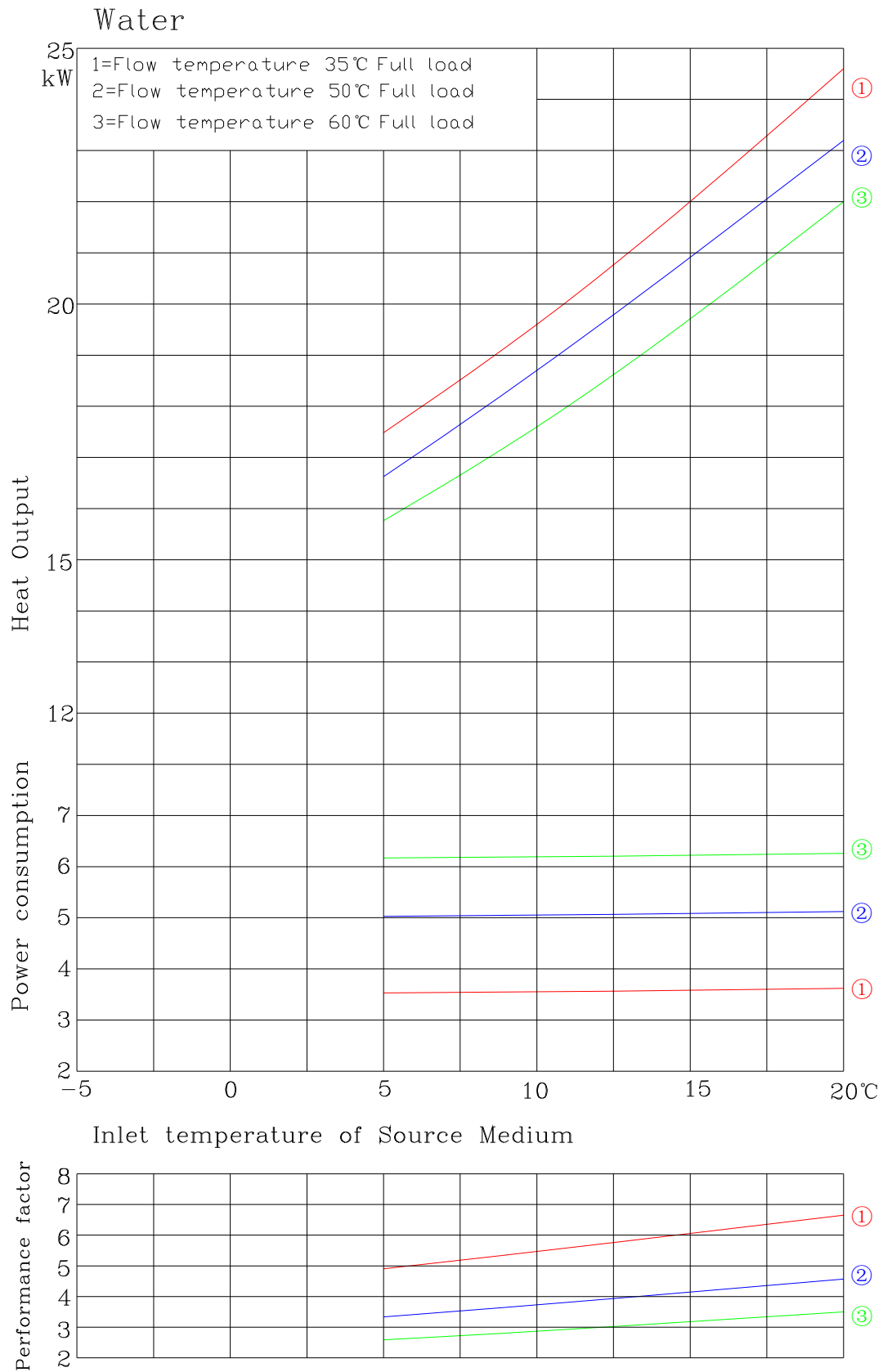

HISEER

Performance Conditions Curve

Model:GSWW20

Water with 33Vol.% ethylene glycol

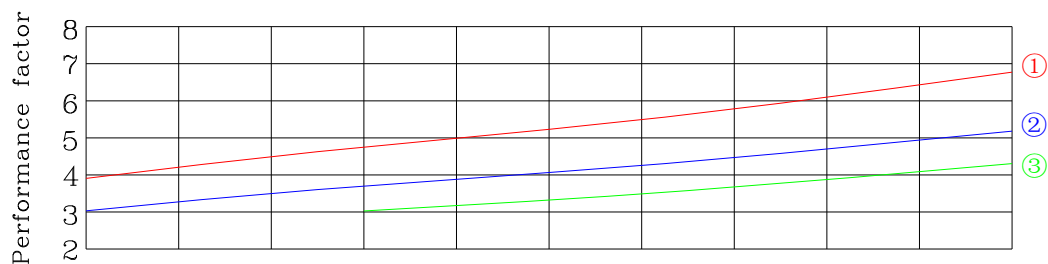
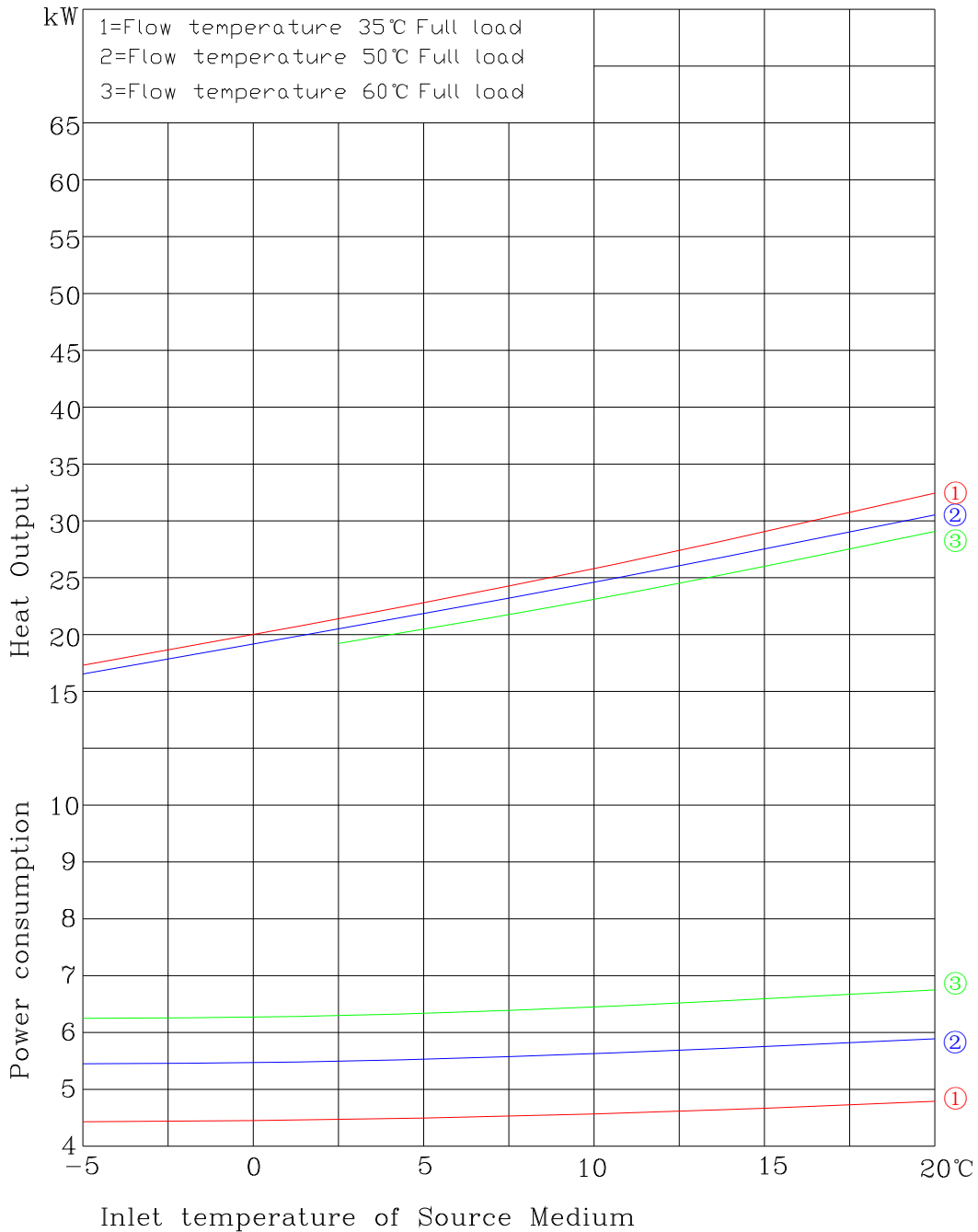

HISEER

Performance Conditions Curve

Model:GSWW20

Water

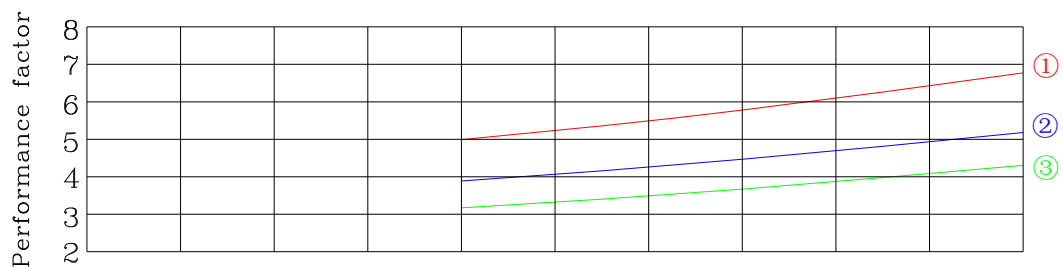
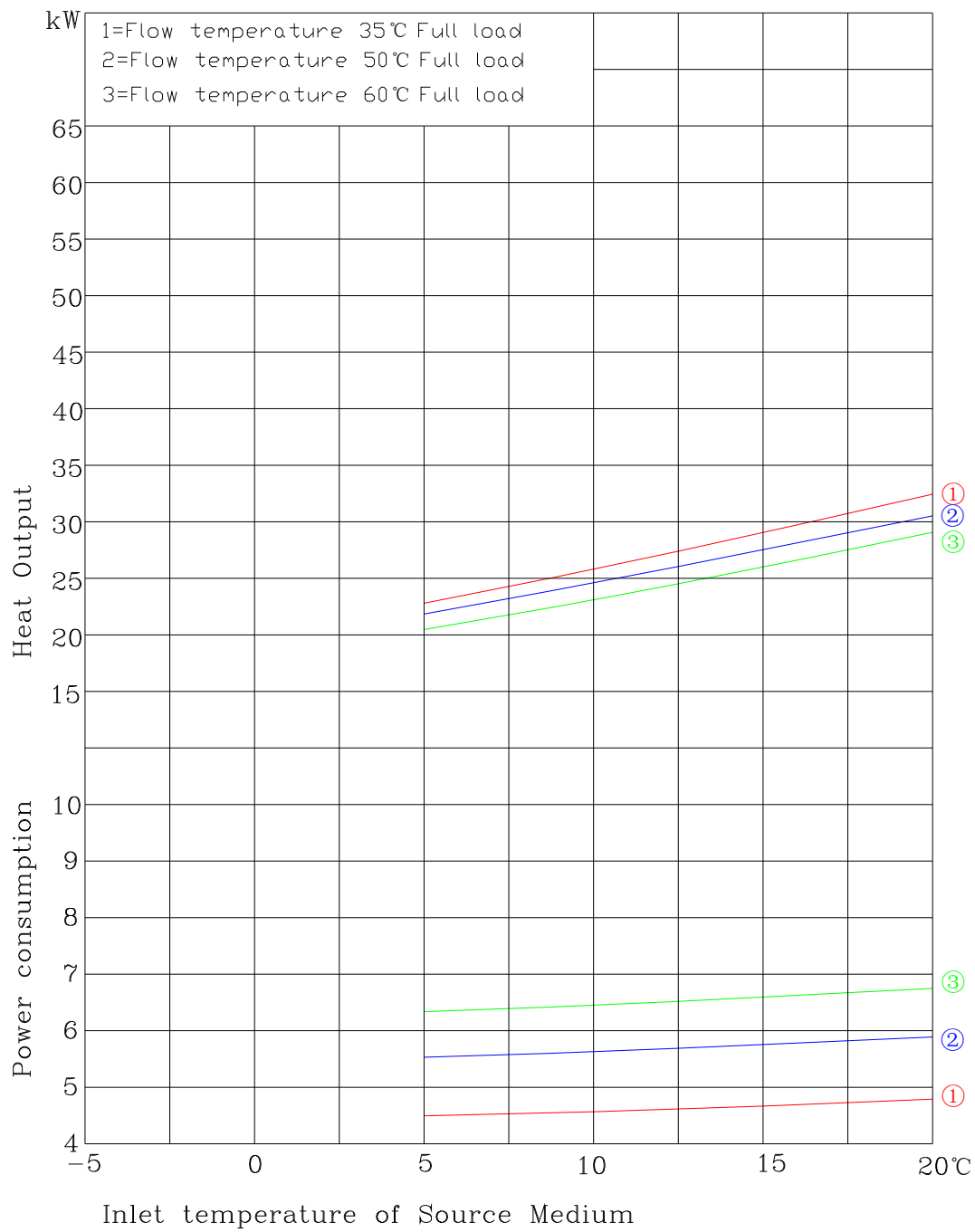

HISEER

Performance Conditions Curve

Model:GSWW26

Water with 33Vol.% ethylene glycol

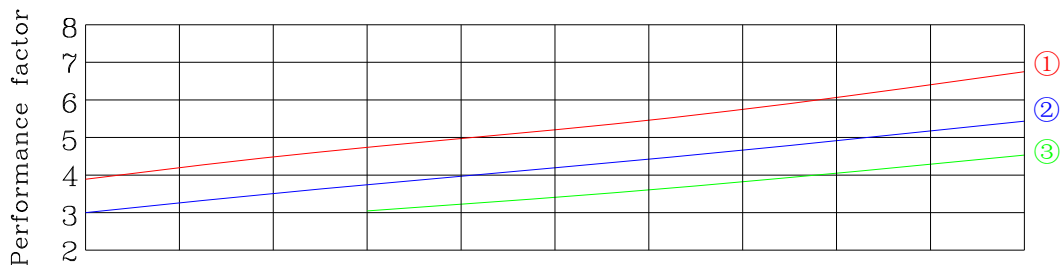
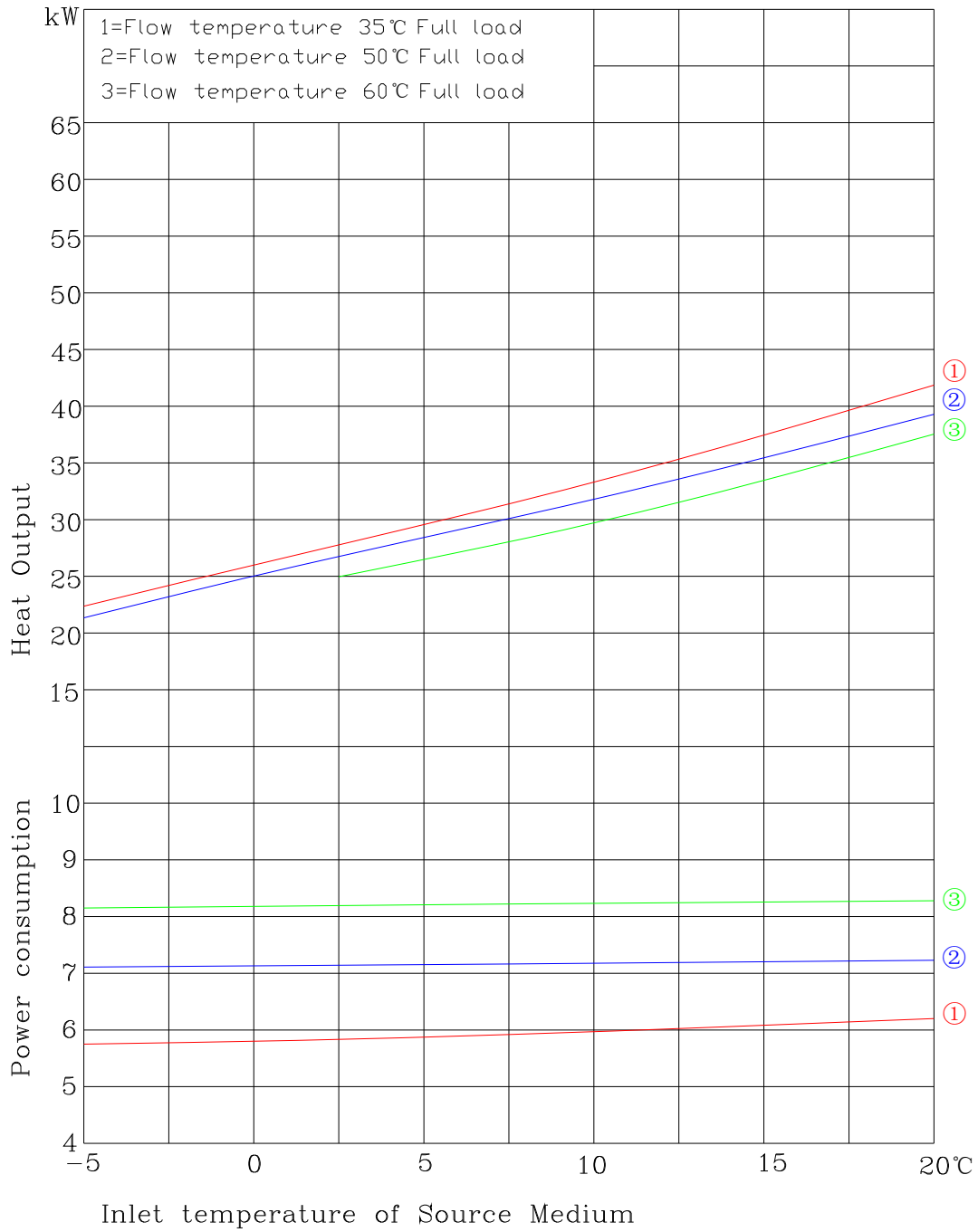

HISEER

Performance Conditions Curve

Model:GSWW26

Water

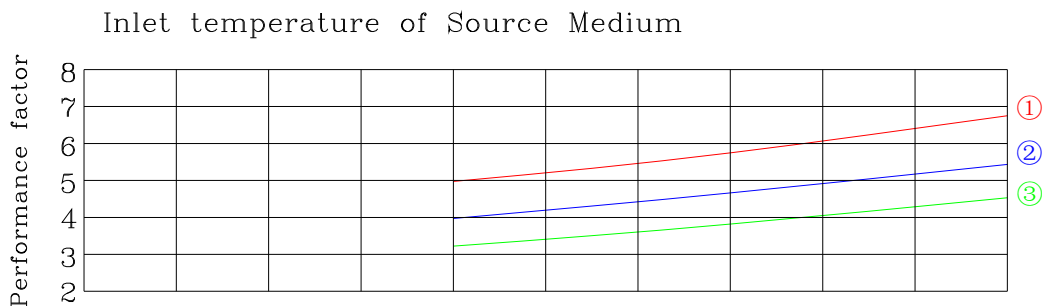
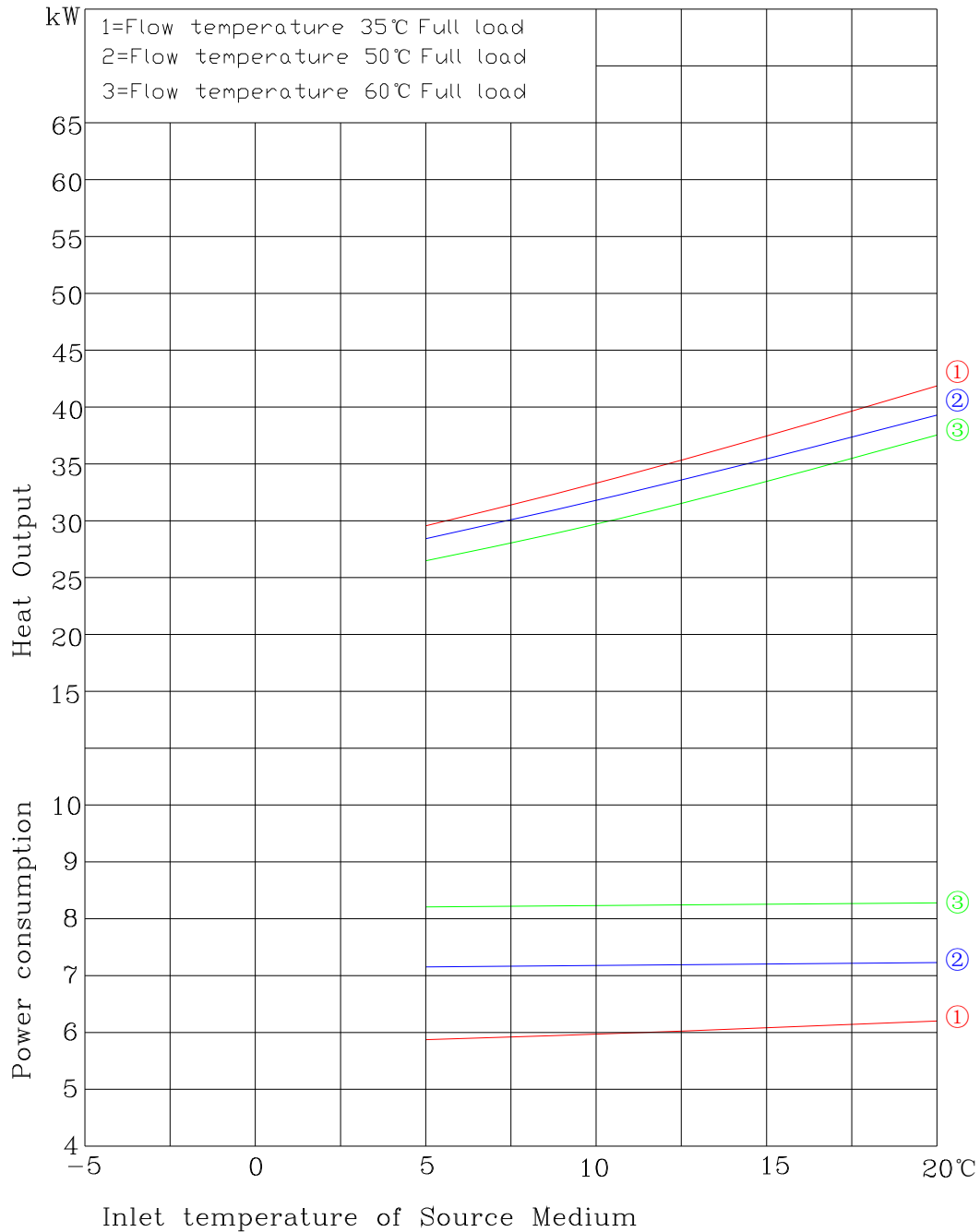

HISEER

Performance Conditions Curve

Model:GSWW30

Water with 33Vol.% ethylene glycol

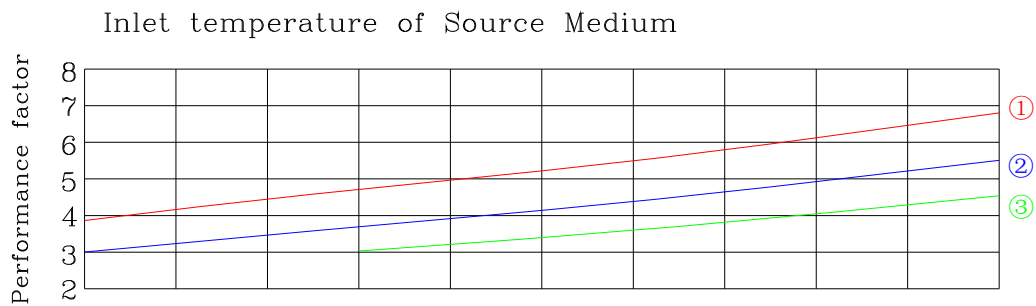
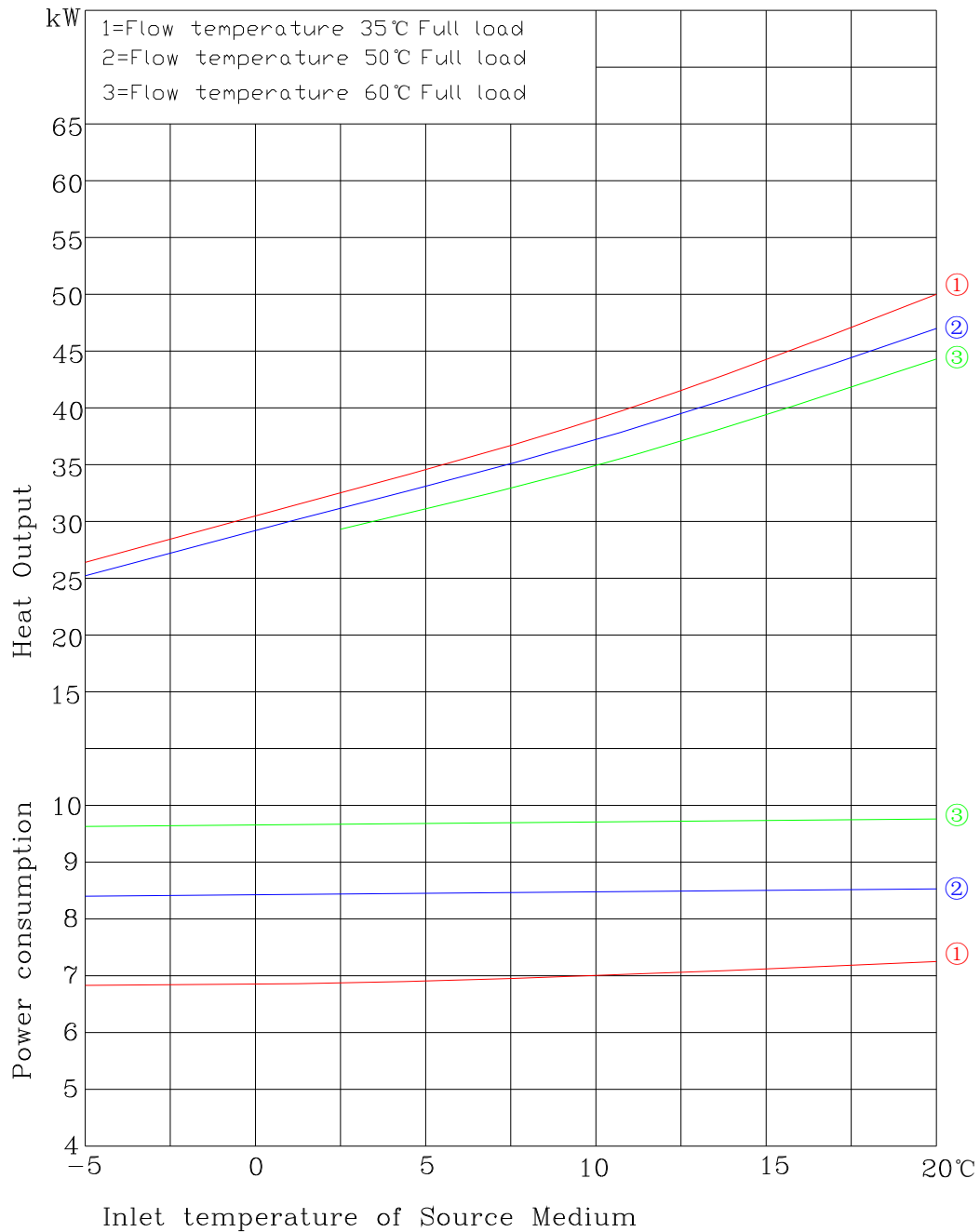

HISEER

Performance Conditions Curve

Model:GSWW30

Water

