



PISTON

PISTON RINGS

TOP RING (CHROME FACE) MARK

SECOND RING (BLACK FACE)

OIL RING (COMBINATION RINGS)

10 mm (0.4 in) SPACER

SIDE RAIL (2)

PISTON PIN CLIP (2)

REASSEMBLY: Do not align the end gap of the clip with the cutout in the piston pin bore.

CLIP

CUTOUT

TOP RING (CHROME FACE)

10 mm

MODEL MARK

CONNECTING ROD WITH THE LONG END

NOTICE: Take care not to break the piston ring when installing the piston assembly in the cylinder.

CONNECTING ROD

PISTON PIN

PISTON

CRANKCASE COVER/GOVERNOR

6 mm THRUST WASHER

GROOVE

GOVERNOR SLIDER

GOVERNOR HOLDER CLIP

GOVERNOR WEIGHT HOLDER ASSEMBLY

6 x 14 (2) 12 N·m (1.2 kgf·m, 9 lbf·ft)

6 mm WASHER

Install inside the case.

GOVERNOR HOLDER SHAFT

GOVERNOR ARM SHAFT

The lock pin must be installed with the straight side of the pin against the groove in the shaft.

GOVERNOR ARM SHAFT

GROOVE

LOCK PIN

8 mm LOCK PIN

OIL PAN

VALVES/FLYWHEEL

VALVE SPRING RETAINER (2)

NOTICE: Do not remove the valve spring retainer while the piston is installed, or the valves will drop into the cylinder.

VALVE SPRING (2)

VALVE STEM SEAL (Intake valve only)

SPARK PLUG

Lawn Mowers: BPR5ES (NGK)

All others: BPR6ES (NGK)

FLYWHEEL

14 mm SPECIAL NUT

Aluminum flywheel: 52 N·m (5.3 kgf·m, 38 lbf·ft)

Cast iron flywheel: 74 N·m (7.5 kgf·m, 54 lbf·ft)

25 x 18 mm SPECIAL WOODRUFF KEY

When installing the flywheel, check to be sure that the woodruff key remains in its slot on the crankshaft.

VALVE GUIDE

EXHAUST VALVE

VALVE HEAD DIAMETER: IN: 25 mm (0.98 in) EX: 24 mm (0.94 in)

INTAKE VALVE

Be careful not to damage the valve stem seal when installing.

CYLINDER BARREL

OIL PAN/CRANKSHAFT/CYLINDER BARREL

GREASE (Apply grease to the oil seal lips.)

28 x 41.25 x 6 mm OIL SEAL

INSTALLATION: Be careful not to damage the lip of the oil seal when installing the crankcase cover with the oil seal.

6 x 25 (8) 12 N·m (1.2 kgf·m, 9 lbf·ft)

OIL PAN ASSEMBLY

8 x 20 mm DOWEL PIN (2)

CRANKSHAFT

INSTALLATION:

- Be careful not to damage the oil seal.
- After installation, clean the crankshaft tapered surface.

THRUST WASHER

PISTON ASSEMBLY

INSTALLATION: Install with the model mark and connecting rod long end to the right side of the cylinder.

TIMING BELT

Specified belt: 84HU7 G-200

INSTALLATION: Check that the belt is not worn or cracked and do not bend or twist the belt.

CONNECTING ROD BOLT (2) 12 N·m (1.2 kgf·m, 9 lbf·ft)

CONNECTING ROD CAP

OIL DIPPER

25.4 x 62 x 6 mm OIL SEAL (Apply grease to the oil seal lips.)

CYLINDER BARREL

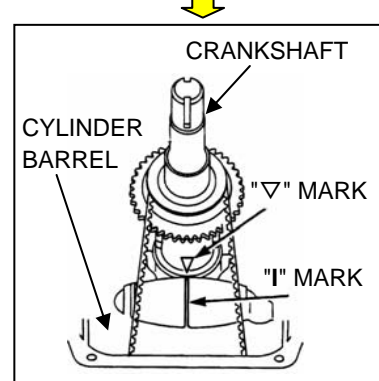
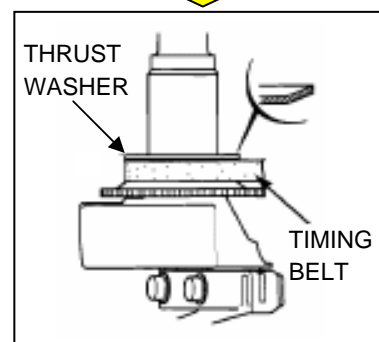
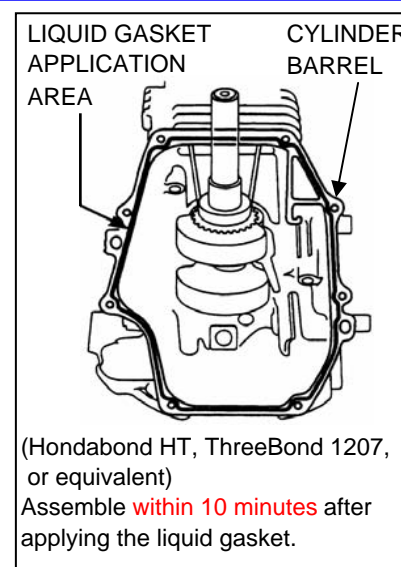
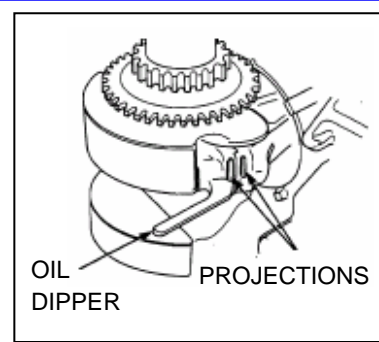

CAM PULLEY/ROCKER ARM/CYLINDER HEAD COVER

CYLINDER HEAD COVER

6 x 12 (4) 12 N·m (1.2 kgf·m, 9 lbf·ft)

VALVE ADJUSTING SCREW (2)

VALVE ADJUSTING LOCK NUT (2)

ROCKER ARM SHAFT (2)

INTAKE ROCKER ARM

TIMING BELT

CAM PULLEY SHAFT

6.8 x 1.9 mm O-RING

Do not reuse.

CYLINDER HEAD COVER VIEWED FROM BACK SIDE:

LIQUID GASKET APPLICATION AREA

- Apply a liquid gasket (Hondabond HT, ThreeBond 1207, or equivalent) to the cylinder head cover.
- Assemble **within 10 minutes** after applying the liquid gasket.
- Wait for **approximately 20 minutes** after assembly before filling with oil and starting the engine.

VIEW FROM PTO SIDE:

ALIGNMENT MARKS

CAM PULLEY

CYLINDER HEAD COVER MATING SURFACE

CRANKSHAFT KEY GROOVE

LAWN MOWER (CBU) MODEL ONLY

- Set the cam pulley on the timing belt with care not to turn the crankshaft.
- Install the cam pulley shaft on the cylinder barrel.

ROCKER ARM SHAFT

Install the rocker arm shaft from the opposite side from the cam pulley as shown.